

Three-phase four-wire power supply dedicated for electricity
High isolation, ultra wide input range, AC-DC module



RoHS

FEATURES

- Ultra wide input voltage range:
65 - 460VAC/90 - 650VDC
- Operating ambient temperature range: -40°C to +70°C
- High I/O isolation test voltage up to 4000VAC (Input - output)
- EFT/Surge: ±4KV Perf. Criteria B
- Output short circuit, over-current, over-voltage protection
- High efficiency, high reliability
- Low ripple & noise, low power consumption

LO10-26D0512-04—Ultra input voltage range switching power supply dedicated for electric meters. This product is a three-phase four-wire power meter switching power supply designed for the public network terminal, special-purpose terminal, large customer terminal and substation terminal according to the latest "State Grid Standard". It operates at a very wide input voltage range: 65-460VAC or 90-650VDC and meets the rated voltage: 380/220VAC (three-phase four-wire) power supply requirements. The input and output isolation voltage up to 4000VAC. It meets IEC/EN61000 standard "EFT (4KV)", "surge (4KV)" and are suitable for various terminal applications requiring high isolation voltage and strict electromagnetic compatibility. For extremely harsh EMC environment, we recommend using the application circuit show in Design Reference of this datasheet.

Selection Guide

Part No.	Output Power	Nominal Output Voltage and Current (Vo/Io)		Efficiency at 230VAC (%) Typ.	Capacitive Load (μF) Max.	
		(Vo1/Io1)	(Vo2/Io2)		Vo1	Vo2
LO10-26D0512-04	10.92W	5.1V/1.2A	12V/0.4A	78	4000	1200

Input Specifications

Item	Operating Conditions	Min.	Typ.	Max.	Unit
Input Voltage Range	AC input	65	--	460	VAC
	DC input	90	--	650	VDC
Input Frequency		47	--	440	Hz
Input Current	100VAC	--	--	0.4	A
Inrush Current	115VAC	--	25	--	
	220VAC	--	40	--	
Leakage Current	220VAC/60Hz	0.25mA RMS Max.			
Input Over-voltage Protection	AC input	490	--	540	VAC
Hot Plug		Unavailable			

Output Specifications

Item	Operating Conditions	Min.	Typ.	Max.	Unit
Output Voltage Accuracy	Full load	Vo1	±2	--	
		Vo2	±10	--	
Line Regulation	Rated load	Vo1	±0.5	--	%
		Vo2	±1.5	--	
Load Regulation	Balanced load, 10%-100% load	Vo1	±3	--	
		Vo2	±5	--	
Ripple & Noise*	20MHz bandwidth (peak-to-peak value)	Vo1	--	100	mV
		Vo2	--	200	
Temperature Coefficient	Vo1	--	±0.02	--	%/°C
Stand-by Power Consumption	220VAC	--	0.55	--	W
Short Circuit Protection		Hiccup, continuous, self-recovery			
Over-current Protection		≥110%Io, self-recovery			

Over-voltage Protection	Vo1	≤7.5VDC		Output voltage clamp	
	Vo2	≤20VDC			
Minimum Load		10	--	--	%
Hold-up Time	230VAC input, Io=100%	--	100	--	ms

Note: * The "parallel cable" method is used for ripple and noise test, please refer to AC-DC Converter Application Notes for specific information.

General Specifications

Item		Operating Conditions	Min.	Typ.	Max.	Unit
Isolation	Input-output	Electric strength test for 1min., leakage current <5mA	4000	--	--	VAC
	Output-output		4000	--	--	
Insulation Resistance	Input-output	500VDC	100	--	--	MΩ
Operating Temperature			-40	--	+70	°C
Storage Temperature			-40	--	+85	
Storage Humidity			--	--	90	%RH
Altitude			--	--	2000	m
Soldering Temperature		Wave-soldering	260 ± 5°C; time: 5 - 10s			
		Manual-welding	360 ± 10°C; time: 3 - 5s			
Switching Frequency			--	60	--	KHz
Power Derating		-40°C to 0°C	0.75	--	--	% / °C
		+60°C to +70°C	3.00	--	--	
		65VAC -85VAC	2.00	--	--	%/VAC
Safety Class			CLASS II			
MTBF			MIL-HDBK-217F@25°C > 300,000 h			

Mechanical Specifications

Dimension	100.00 x 50.00 x 34.00 mm
Weight	85g (Typ.)
Cooling Method	Free air convection

Electromagnetic Compatibility (EMC)

Emissions	CE	CISPR32/EN55032 CLASS B		
	RE	CISPR32/EN55032 CLASS B		
Immunity	ESD	IEC/EN 61000-4-2	Contact ±6KV/Air ±8KV	Perf. Criteria B
	RS	IEC/EN 61000-4-3	10V/m	perf. Criteria A
	EFT	IEC/EN 61000-4-4	±4KV	perf. Criteria B
	Surge	IEC/EN 61000-4-5	±2KV	perf. Criteria B
			±4.4KV (See Fig.2, 3 for recommended circuit)	perf. Criteria B
	CS	IEC/EN61000-4-6	10Vr.m.s	perf. Criteria A
	PFM	IEC/EN61000-4-8	10A/m	perf. Criteria A
Voltage dips, short interruptions and voltage variations immunity		IEC/EN61000-4-11	100% dip 1 periods, 30% dip 25 periods, 100% interruptions 250 periods	perf. Criteria B

Product Characteristic Curve

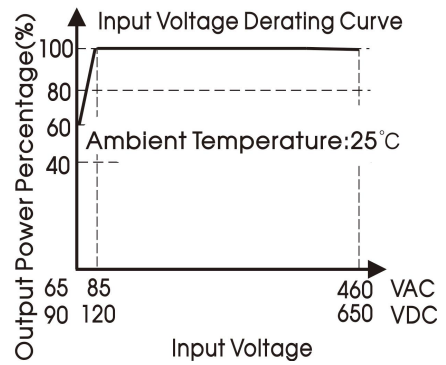
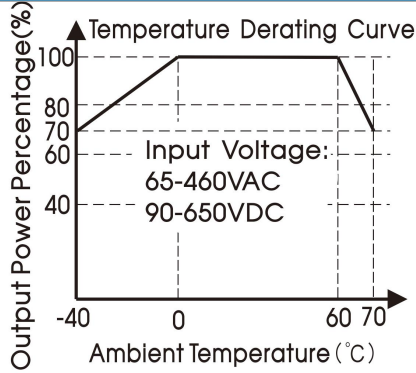

Note: ① With an AC input between 65-85VAC and a DC input between 90-120VDC, the output power must be derated as per temperature derating curves;
② This product is suitable for applications using natural air cooling; for applications in closed environment please consult factory or one of our FAE.

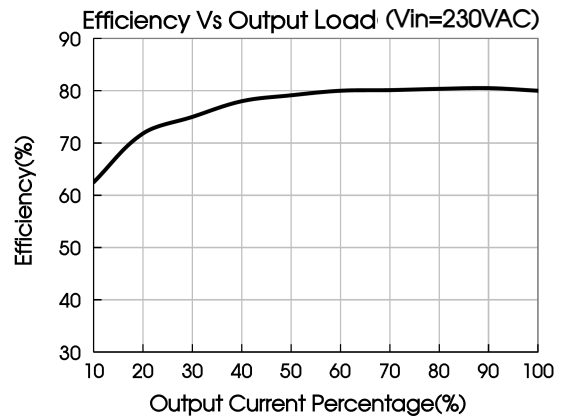
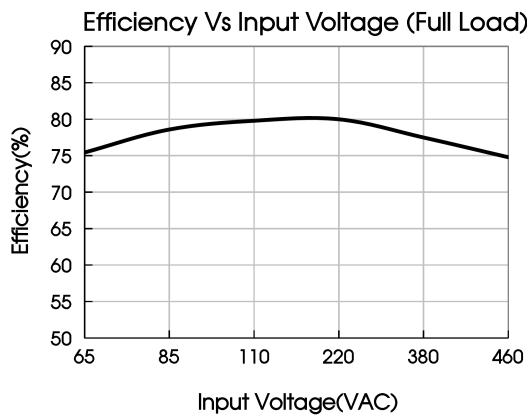

Design Reference

1. Typical application

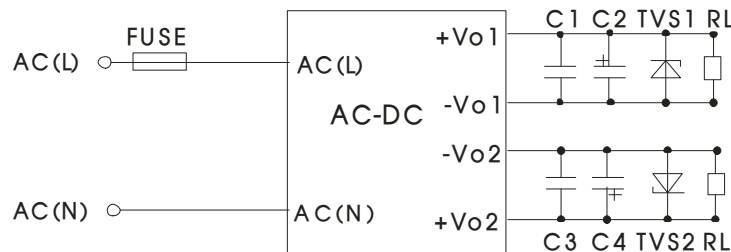

Fig. 1

Part No.	C1, C3	C2, C4	TVS1	TVS2	FUSE
LO10-26D0512-04	0.1μF/50V	220μF/25V	P6KE6.8A	SMBJ20A	3.15A/500VAC, slow-blow, required

Output Filter Components:

We recommend using an electrolytic capacitor with high frequency, and low ESR rating for C2, C4 (refer to manufacture's datasheet). C1, C3 are ceramic capacitors used for filtering high-frequency noise. Choose a capacitor voltage rating with at least 20% margin, in other words not exceeding 80%. And TVS is a recommended suppressor diode to protect the application in case of a converter failure.

2. EMC compliance recommended circuit

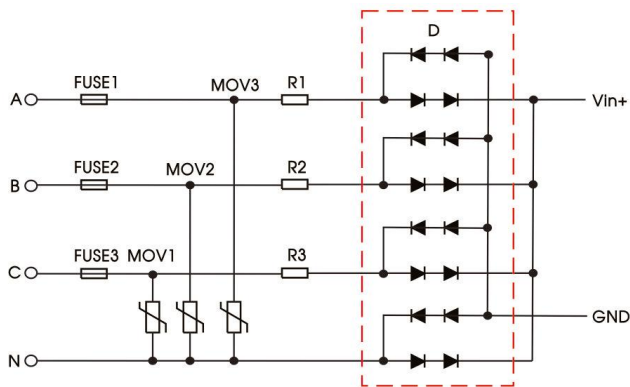

Fig. 2: Recommended circuit for applications which require 4.4KV differential-mode surge standard (full-wave rectification)

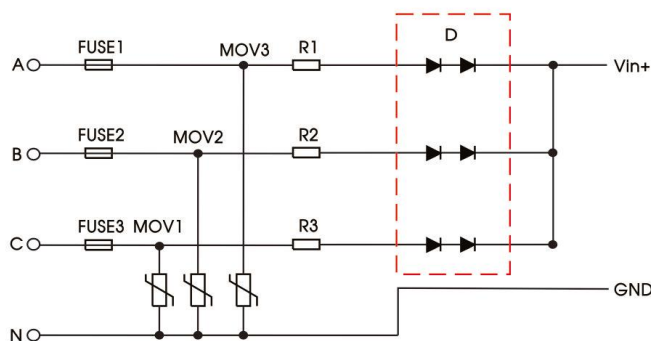



Fig. 3: Recommended circuit for applications which require 4.4KV differential-mode surge standard (half-wave rectification)

Recommend Parameter For Higher EMC Standard Circuit	
Component	Recommended value
MOV1, MOV2, MOV3	S20K510
D	2A/1000V
R1, R2, R3	10Ω/5W
FUSE1, FUSE2, FUSE3	3.15A/500VAC, slow-blow, required

3. For additional information please refer to application notes on www.mornsun-power.com.

Dimensions and Recommended Layout

THIRD ANGLE PROJECTION 

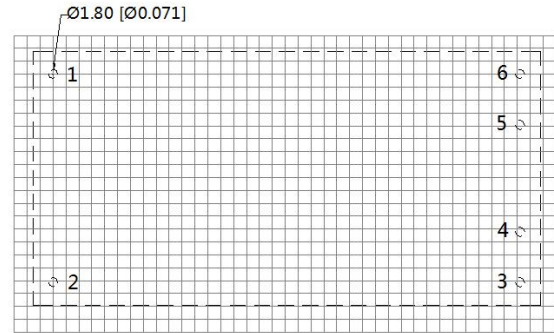
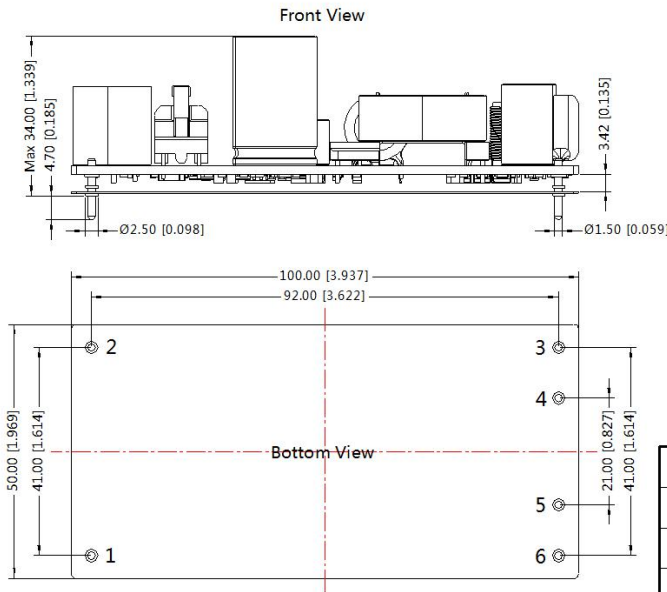

Note: Grid 2.54*2.54mm

Pin	Name	Function
1	AC(L)	AC voltage line wire(L wire) or positive input voltage (DC)
2	AC(N)	AC voltage neutral wire(N wire) or negative input voltage(DC)
3	+Vo2	The second output voltage positive(+)
4	-Vo2	The second output voltage negative(-)
5	-Vo1	The first output voltage negative(-)
6	+Vo1	The first output voltage positive(+)

Note:
1.Unit: mm[inch]
2.General tolerances: $\pm 0.50[\pm 0.020]$
3.PCB is FR-4,1.6mm thick double-sided glass fiber board
4.Insulation sheet material is 0.40mm black mylar sheet

Note:

- For additional information on Product Packaging please refer to www.mornsun-power.com. Packaging bag number: 58220192;
- If the product is not operated within the required load range, the product performance cannot be guaranteed to comply with all parameters in the datasheet;
- Unless otherwise specified, parameters in this datasheet were measured under the conditions of $T_a=25^\circ\text{C}$, humidity<75% with nominal input voltage and rated output load;
- All index testing methods in this datasheet are based on our company corporate standards;
- We can provide product customization service, please contact our technicians directly for specific information;
- Products are related to laws and regulations: see "Features" and "EMC";
- Our products shall be classified according to ISO14001 and related environmental laws and regulations, and shall be handled by qualified units.

Mornsun Guangzhou Science & Technology Co., Ltd.

Address: No. 5, Kehui St. 1, Kehui Development Center, Science Ave., Guangzhou Science City, Huangpu District, Guangzhou, P. R. China
Tel: 86-20-38601850 Fax: 86-20-38601272 E-mail: info@mornsun.cn www.mornsun-power.com