

- High power block with excellent thermal convection
- Operating temperature -40°C to +75°C without derating
- Increased shock & vibration resistance
- Ultra wide 4:1 input voltage range
- EN 50155 approval for railway applications
- Excellent efficiency up to 90%
- Input filter meet EN 55022, class A
- I/O insulation 1591 VAC
- Under voltage lock-out circuit



The TEQ 160WIR Series is a family of isolated high performance DC/DC converter modules with ultra-wide 4:1 input voltage ranges which come in a rugged, sealed metal case.

These converters are suitable for a wide range of applications, but the product is designed particularly also for industrial applications where often no PCB mounting is possible but the module has to be mounted on a chassis. A very high efficiency and the overall heatsink construction allows an operating temperature up to +75°C with natural convection cooling without power derating and up to +90°C with power derating. Further features include output voltage trimming, Remote On/Off and under voltage lockout. The very wide input voltage range and reverse input voltage protection make these converters also an interesting solution for battery operated systems.

### Models

Order Code	Input Voltage Range	Output Voltage nom. (adjustable)	Output Current max.	Efficiency typ.
TEQ 160-4812WIR	19 - 75 VDC (48 VDC nom.)	12 VDC (9.6 - 13.2 VDC)	13'000 mA	90 %
TEQ 160-4815WIR		24 VDC (19.2 - 26.4 VDC)	6'500 mA	90 %
TEQ 160-4816WIR		28 VDC (22.4 - 30.8 VDC)	5'500 mA	90 %
TEQ 160-4818WIR		48 VDC (38.4 - 52.8 VDC)	3'200 mA	90 %
TEQ 160-7212WIR	43 - 160 VDC (110 VDC nom.)	12 VDC (9.6 - 13.2 VDC)	15'000 mA	89 %
TEQ 160-7215WIR		24 VDC (19.2 - 26.4 VDC)	7'500 mA	89 %
TEQ 160-7216WIR		28 VDC (22.4 - 30.8 VDC)	6'500 mA	89 %
TEQ 160-7218WIR		48 VDC (38.4 - 52.8 VDC)	3'800 mA	89 %

### Options

TEQ-MK1	- Optional DIN-Rail Mounting Kit: <a href="http://www.tracopower.com/products/teq-mk1.pdf">www.tracopower.com/products/teq-mk1.pdf</a>
---------	--

### Input Specifications

Input Current	- At no load	110 Vin models: <b>10 mA typ.</b> 48 Vin models: <b>20 mA typ.</b> (12 Vout model) <b>20 mA typ.</b> (24 Vout model) <b>20 mA typ.</b> (28 Vout model) <b>25 mA typ.</b> (48 Vout model)
Surge Voltage		48 Vin models: <b>100 VDC max.</b> (1 s max.) 110 Vin models: <b>185 VDC max.</b> (1 s max.)
Under Voltage Lockout		48 Vin models: <b>15.5 VDC min. / 16.5 VDC typ. / 18 VDC max.</b> 110 Vin models: <b>33 VDC min. / 35.5 VDC typ. / 38 VDC max.</b>
Recommended Input Fuse		(The need of an external fuse has to be assessed in the final application.)
Input Filter		<b>Internal Common Mode Choke + Pi-Type</b>

### Output Specifications

Output Voltage Adjustment		<b>-20% to +10%</b> (By trim potentiometer) Output power must not exceed rated power!
Voltage Set Accuracy		<b>±1% max.</b>
Regulation	- Input Variation (Vmin - Vmax) - Load Variation (0 - 100%)	<b>0.1% max.</b> <b>0.1% max.</b>
Ripple and Noise (20 MHz Bandwidth)		12 Vout models: <b>100 mVp-p typ.</b> 24 Vout models: <b>200 mVp-p typ.</b> 28 Vout models: <b>200 mVp-p typ.</b> 48 Vout models: <b>300 mVp-p typ.</b> 12 Vout models: <b>125 mVp-p max.</b> 24 Vout models: <b>250 mVp-p max.</b> 28 Vout models: <b>250 mVp-p max.</b> 48 Vout models: <b>350 mVp-p max.</b>
Capacitive Load	- 48 Vin input  - 110 Vin input	12 Vout models: <b>10'800 µF max.</b> 24 Vout models: <b>2'700 µF max.</b> 28 Vout models: <b>1'900 µF max.</b> 48 Vout models: <b>660 µF max.</b> 12 Vout models: <b>12'500 µF max.</b> 24 Vout models: <b>3'100 µF max.</b> 28 Vout models: <b>2'300 µF max.</b> 48 Vout models: <b>790 µF max.</b>
Minimum Load		<b>Not required</b>
Temperature Coefficient		<b>±0.02 %/K max.</b>
Start-up Time		<b>75 ms typ.</b>
Short Circuit Protection		<b>Continuous, Automatic recovery</b>
Output Current Limitation		<b>120 - 150% of Iout max.</b>
Overvoltage Protection		<b>115 - 130% of Vout nom.</b>
Transient Response	- Response Time	<b>200 µs typ. / 250 µs max.</b> (25% Load Step)

### Safety Specifications

Safety Standards	- IT / Multimedia Equipment  - Industrial Control Equipment  - Railway Applications - Certification Documents	<b>EN 62368-1</b> <b>IEC 62368-1</b> <b>UL 62368-1</b> <b>UL 508</b> <b>CSA-C22.2, No. 107.1</b> <b>EN 50155</b> <a href="http://www.tracopower.com/overview/teq160wir">www.tracopower.com/overview/teq160wir</a>
Pollution Degree		<b>PD 2</b>

All specifications valid at nominal voltage, resistive full load and +25°C after warm-up time, unless otherwise stated.

## EMC Specifications

<b>EMI Emissions</b>		EN 50121-3-2 (EMC for Rolling Stock)
- Conducted Emissions		EN 55011 class A (internal filter)
		EN 55032 class A (internal filter)
- Radiated Emissions		EN 55011 class A (internal filter)
		EN 55032 class A (internal filter)
<b>EMS Immunity</b>		EN 50155 (Railway Applications)
		EN 50121-3-2 (EMC for Rolling Stock)
		EN 55024 (IT Equipment)
		EN 55035 (Multimedia)
		EN 61204-3 (Low Voltage Power Supplies)
- Electrostatic Discharge	Air:	EN 61000-4-2, ±8 kV, perf. criteria A
	Contact:	EN 61000-4-2, ±6 kV, perf. criteria A
- RF Electromagnetic Field		EN 61000-4-3, 20 V/m, perf. criteria A
- EFT (Burst) / Surge		EN 61000-4-4, ±2 kV, perf. criteria A
		EN 61000-4-5, ±1 kV, perf. criteria A
		EN 61000-4-5, ±2 kV, perf. criteria A
- Conducted RF Disturbances		EN 61000-4-6, 10 Vrms, perf. criteria A
- PF Magnetic Field	Continuous:	EN 61000-4-8, 100 A/m, perf. criteria A

## General Specifications

<b>Relative Humidity</b>		95% max. (non condensing)
<b>Temperature Ranges</b>	- Operating Temperature	-40°C to +90°C
	- Storage Temperature	-40°C to +105°C
<b>Power Derating</b>	- High Temperature	Depending on model
		See application note: <a href="http://www.tracopower.com/overview/teq160wir">www.tracopower.com/overview/teq160wir</a>
<b>Over Temperature Protection Switch Off</b>	- Protection Mode	105°C min. / 115°C typ. / 120°C max. (Automatic recovery)
<b>Cooling System</b>		Natural convection (20 LFM)
<b>Sense Function</b>		10% max. of Vout nom.
<b>Remote Control</b>	- Voltage Controlled Remote	On: 3.0 to 12 VDC or open circuit
		Off: 0 to 1.2 VDC or short circuit
		Refers to 'Remote' and '-Vin' Pin
	- Off Idle Input Current	8 mA max.
	- Remote Pin Input Current	-0.5 to 1.0 mA
<b>Altitude During Operation</b>		2'000 m max.
<b>Switching Frequency</b>		225 - 275 kHz (PWM)
		250 kHz typ. (PWM)
<b>Insulation System</b>		Reinforced Insulation
<b>Working Voltage (rated)</b>		182 VAC
<b>Isolation Test Voltage</b>	- Input to Output, 60 s	2'250 VDC
	- Input to Case, 60 s	1'600 VDC
	- Output to Case, 60 s	1'600 VDC
<b>Isolation Resistance</b>	- Input to Output, 500 VDC	1'000 MΩ min.
<b>Reliability</b>	- Calculated MTBF	400'000 h (MIL-HDBK-21 7F at 55°C, ground benign)
<b>Environment</b>	- Vibration	MIL-STD-810F
		EN 61373
	- Mechanical Shock	MIL-STD-810F
		EN 61373
	- Thermal Shock	MIL-STD-810F
		EN 50155
<b>Housing Material</b>		Aluminum
<b>Potting Material</b>		Silicone (UL 94 V-0 rated)
<b>Housing Type</b>		Metal Case
<b>Mounting Type</b>		Chassis Mount

All specifications valid at nominal voltage, resistive full load and +25°C after warm-up time, unless otherwise stated.

Connection Type	Spring Clamps
Weight	800 g
Thermal Impedance	- Case to Ambient 1.45 K/W typ.
Environmental Compliance	- REACH Declaration <a href="http://www.tracopower.com/info/reach-declaration.pdf">www.tracopower.com/info/reach-declaration.pdf</a> REACH SVHC list compliant REACH Annex XVII compliant - RoHS Declaration <a href="http://www.tracopower.com/info/rohs-declaration.pdf">www.tracopower.com/info/rohs-declaration.pdf</a> Exemptions: 7a, 7c-I (RoHS exemptions refer to the component concentration only, not to the overall concentration in the product (O5A rule). The SCIP number is provided on request.) - Flammability (EN 45545-2) <a href="http://www.tracopower.com/info/en45545-declaration.pdf">www.tracopower.com/info/en45545-declaration.pdf</a>

### Supporting Documents

Overview Link (for additional Documents)

[www.tracopower.com/overview/teq160wir](http://www.tracopower.com/overview/teq160wir)

### Outline Dimensions

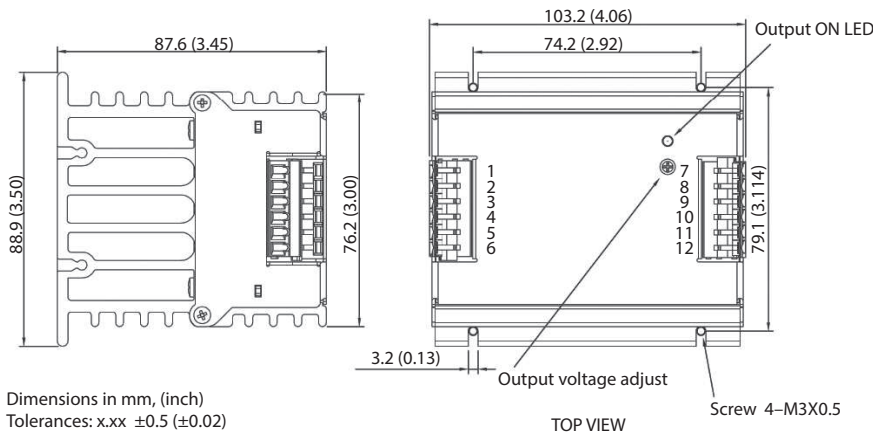

Terminal connection		
Terminal	Pin Function	Recommended Wire
1,2	-Vin	12 AWG
3	NC	NC
4	On/Off Ctrl	14 - 18 AWG
5, 6	+Vin	12 AWG
7, 8	-Vout	12 AWG
9	-Sense*	14 - 18 AWG
10	+Sense*	14 - 18 AWG
11, 12	+Vout	12 AWG

NC: No Connection

- \* Sense line to be connected to the output either at the module or at the load under regard of polarity.
- The current rating of the terminal block is 15 A/pole.
- Using 2 poles in parallel if the peak output current can exceed 15 A.
- Wire size shall be selected to withstand the peak output current (I<sub>out max</sub> + Current limitation).