



Typical Features

- ◆ Ultra Wide input voltage range 200-1200VDC (6:1)
- ◆ Against reverse protection, output over-voltage protection, short circuit protection
- ◆ No load input current as low as 1.0mA
- ◆ Input output isolation: 4000VDC
- ◆ High efficiency, high reliability, low ripple noise
- ◆ Widely used in photovoltaic power generation, high-voltage inverter
- ◆ Operating Temperature: -30°C ~ +70°C
- ◆ Industrial design, international pin out



Application Field

BK40-600SXXW2 series -- It is a 200-1200VDC ultra-wide, ultra-high voltage input, high-efficiency and high-reliability DC-DC regulated power supply module, It can be widely used in photovoltaic power generation and high-voltage frequency conversion and other occasions, providing stable working voltage for load equipment, and its own multiple protection functions It can improve the safety performance of the power supply and its load when the module power supply works abnormally.

Typical Product List

Model	Power (W)	Input Current (Input Nominal)		Output Voltage/Current		Output Efficiency (Input Nominal) %/TYP	Max. Capacitive Load (u F)
		Output no load	Output full load	Voltage	Current		
		(mA)		(V)	(mA)		
*BK40-600S12W2	40	0.42	80.3	12	3334	83	2000
BK40-600S15W2		0.46	79.3	15	2667	84	1500
BK40-600S24W2		0.50	78.4	24	1667	85	680

Note 1: Due to space limitations, above is only a part of our product list, please contact our sales team for more items.

Note 2: "*" is model under developing.

Note 3: The typical output efficiency is based on that product is full loaded and burned-in after half an hour.

Note 4: The fluctuation range of full load efficiency(% ,TYP) is $\pm 2\%$, full load output efficiency= total output power/module's input power.

Note 5: When the product input is 300-1200VDC, it is necessary to connect a current limiting resistor (100Ω/10W, metal oxide film) in series to the input end of the module to suppress the surge current.

Please refer to the following peripheral recommended circuit for the specific connection method.

Input Specification

Item	Operating Condition	Min.	Typ.	Max.	Unit
Input Voltage Range	--	200	600	1200	VDC
		Please refer to the Input Voltage Dearting Curve at back			
Item	Operating Condition	Min.	Typ.	Max.	Unit
Input Current	200VDC@100% load	--	245	--	mA
	600VDC@100% load	--	80	--	
	1200VDC@100% load	--	41	--	
Stand-by Consumption	Output no load, nominal input	--	0.9	--	W
Input filtering	IIfilter				

Output Specification

Item	Operating Condition	Min.	Typ.	Max.	Unit
Output Voltage Accuracy	0%~100% load	--	±3.0	±5.0	%
Minimum Load	--	10	--	--	
Line Regulation	Input full load range	--	±0.5	±1.2	
Load Regulation	20%~100% nominal load, balance load	--	±1.0	±2.0	
Ripple & Noise	20MHz bandwidth (peak peak value)	--	150	300	mV
Temperature Coefficient	--	--	--	±0.03	%
Turn-on delay time	200VDC	--	1000	--	mS
	600VDC	--	1000	--	
	1200VDC	--	1000	--	
Power off Holding time	1200VDC	--	10	--	
Turn on overshoot	0%~100% load	--	--	10	%
Dynamic Response Overshoot Range	25%-50%-25%	--	±5.0	±6.0	
Dynamic Response recovery time	50%-75%-50%	--	--	500	mS
Overcurrent protection	Input 200-1200VDC	≥110% Io self-recovery			
Short circuit protection	Input 200-800VDC	Output continuous short circuit protection, after circuit failure is relieved, self-recovery			

General Specification

Item	Operating Condition	Min.	Typ.	Max.	Unit
Isolation Voltage	Input-Output, Test time: 1min@0.5mA	4000	--	--	VDC
Operating Temperature	--	-30	--	+70	℃
	Refer to Temperature Derating Curve, details see the Product Character Curve at back				
Storage Temperature	--	-25	--	+85	
Soldering Temperature	Wave-soldering	260±5℃, time: 5-10S			
	Manual-welding	380±10℃, time: 4-10S			
Switching Frequency	--	--	65	70	KHz
Max. Case Temperature	Within operating Curve	--	--	+100	℃
Shortage Humidity	No condensing	--	--	95	%RH
Insulation Resistance	Input-Output	--	--	500	VDC
		--	--	100	MΩ

Physical Specifications

Case Material		Black Aluminum Case
Package Dimensions	Horizontal package	89.00X63.50X25.50mm
Product Weight		235g (TYP)
Cooling Method		Natural air cooling

Typical Application Circuit

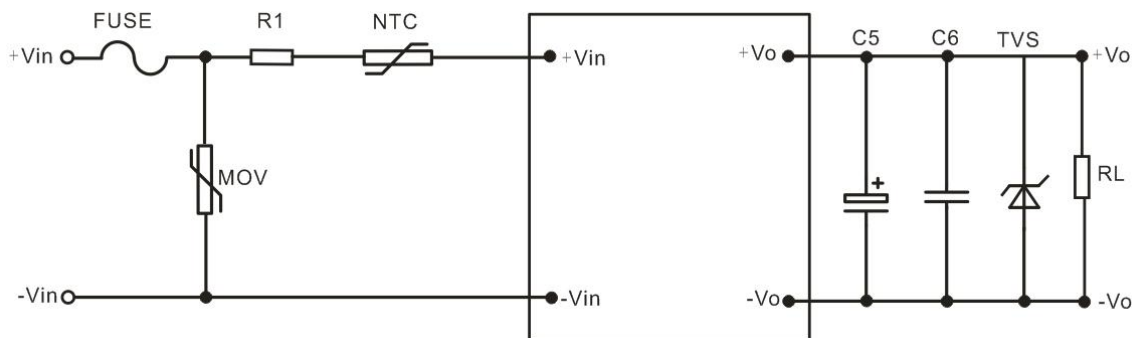

Output Voltage	C5	C6	TVS
12V	680uF/25V	1.0uF/25V/1206	SMBJ15A
15V	470uF/35V	0.2uF/50V/1206	SMBJ18A
24V	330uF/50V	0.1uF/50V/1206	SMBJ28A

EMC External Recommended Circuit

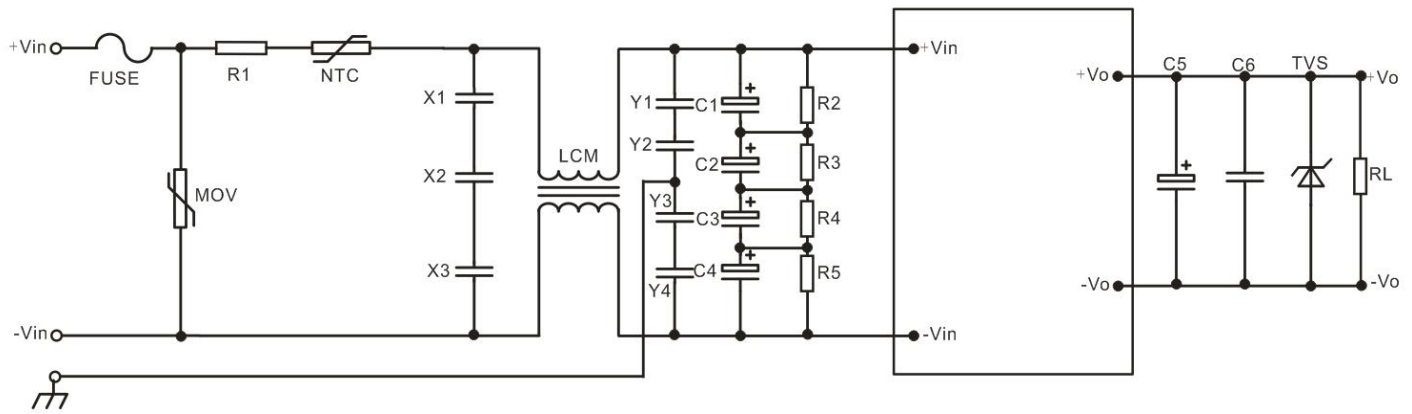

Component	Function	Recommended Value	Note
FUSE	Protect circuit when circuit fails	According to customer's request	Must add
R1	Reject surge current at startup	370Ω/10W Metal oxide film resistance	
NTC	Reject Surge Current	5D-15	
MOV	Absorb lightning surge	20D152K	According to the actual application requirements to select additional
X1/X2/X3	Reject different mode interference	Using 3pcs capacitance: 1.0μF/450V in series connection	
LCM	Reject the common mode interference	8mH/0.8A	
Y1/Y2/Y3/Y4		Using 4pcs capacitance: 2.2nF/400V in series connection	
C1/C2/C3/C4	Low frequency Filter	220uF/450V	
R2/R3/R4/R5	Average Voltage, ensure the equal voltage of capacitance	1MΩ/2W	

Dimension and Pin out Specifications

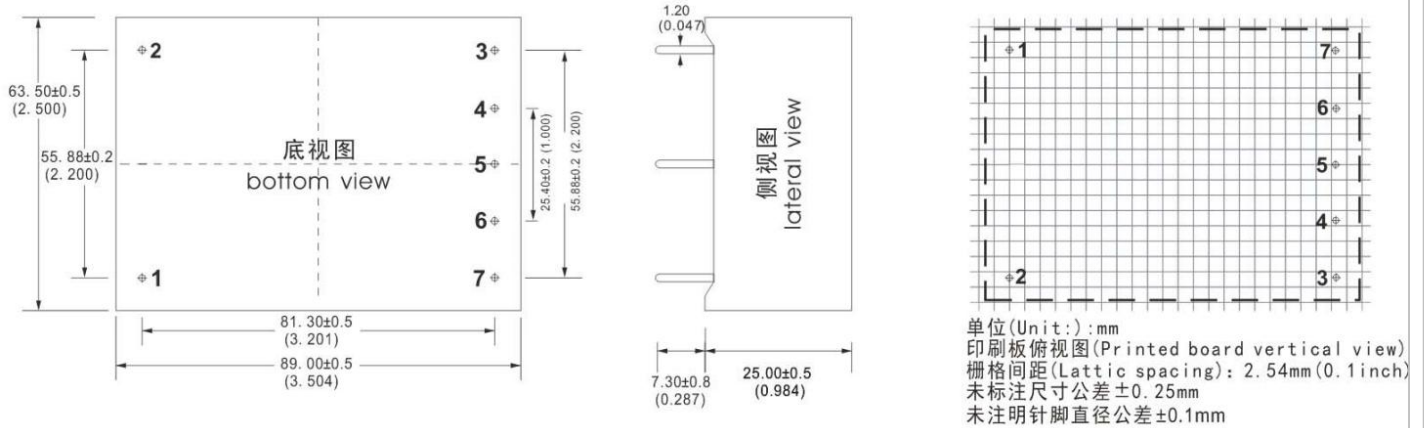

Pin out Specification:

Pin-out	1	2	3	4	5	6	7
Single (S)	-Vin	+Vin	NC	NC	-Vo	NC	+Vo

Dimension

Packing code	L x W x H	
W2	89.00X63.50X25.50mm	3.504X2.500X0.984inch

Ripple & Noise Test: (Twisted Pair Method 20MHZ bandwidth)

Test Method:

(1) 12# twisted pair to connect, Oscilloscope bandwidth set as 20MHz, 100M bandwidth probe, terminated with 0.1uF polypropylene capacitor and 10uF high frequency low resistance electrolytic capacitor in parallel, oscilloscope set as Sample pattern.

(2) Input terminal connect to power supply, output terminal connect to electronic load through jig plate, Use 30cm±2 cm sampling line, Power line selected from corresponding diameter wire with insulation according to the flow of output current.

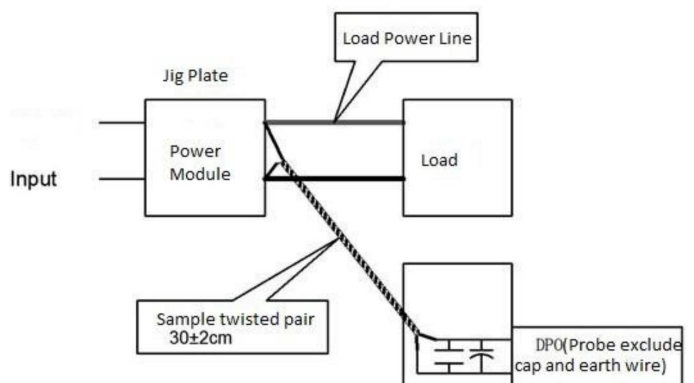

Product Characteristic Curve

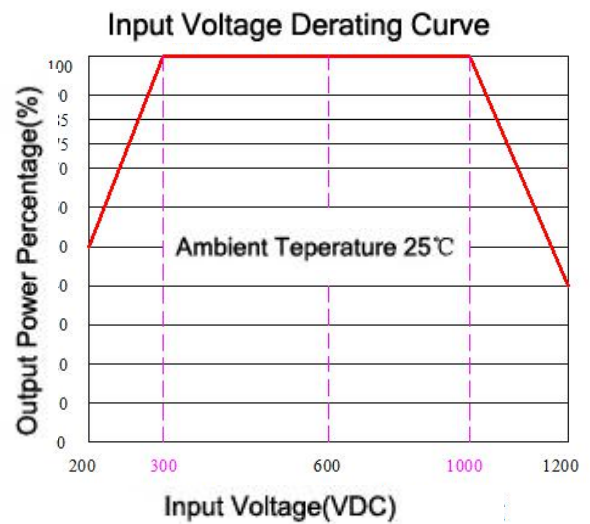
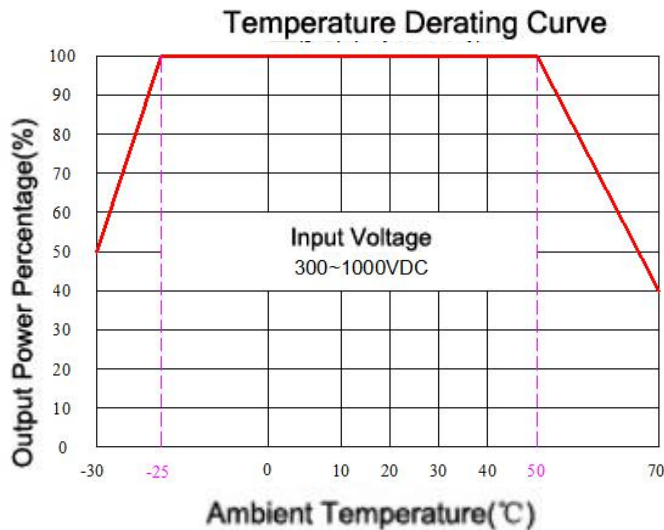

Note:

- 1.The product should be used under the specification range, otherwise it will cause permanent damage to it.
- 2.Product's input terminal should connect to fuse;
- 3.If the product operated below the minimum load request, we cannot ensure that the performance of product is in accordance with all the indexes in this manual;
- 4.If the product worked beyond the load range, we cannot ensure that the performance of product is in accordance with all the indexes in this manual;
- 5.Unless otherwise specified, data in this datasheet are tested under conditions of $T_a=25^{\circ}\text{C}$, humidity<75% when inputting nominal voltage and outputting rated load(pure resistance load);
- 6.All index testing methods in this datasheet are based on our Company's corporate standards.
- 7.The performance indexes of the product models listed in this manual are as above, but some indexes of non-standard model products will exceed the above-mentioned requirements, please directly contact our technician for specific information;
- 8.We can provide customized product service;
- 9.The product specification may be changed at any time without prior notice.